

Register your instrument!
www.eppendorf.com/myeppendorf



Top Buret™

Operating manual

Copyright© 2013 Eppendorf AG, Hamburg. No part of this publication may be reproduced without the prior permission of the copyright owner.

Eppendorf and the Eppendorf logo are a registered trademark of Eppendorf AG.

Trademarks are not marked in all cases with TM or [®] in this manual.

Table of contents

1	Operating instructions	5
1.1	Using this manual	5
1.2	Danger symbols and danger levels	5
1.2.1	Danger symbols	5
1.2.2	Danger levels	5
1.3	Symbols used	6
1.4	Abbreviations used	6
2	Product description	7
2.1	Main illustration	7
2.2	Delivery package	9
2.3	Features	9
2.4	Materials	10
3	Safety	11
3.1	Intended use	11
3.2	User profile	12
3.3	Warnings for intended use	13
3.4	Information on product liability	14
4	Installation	15
4.1	Mounting the device	15
4.2	Inserting the batteries	17
4.3	Mounting the telescopic aspirating tube	18
4.3.1	Extending the telescopic aspirating tube	18
4.3.2	Shortening the telescopic aspirating tube	18
4.3.3	Mounting the telescopic aspirating tube	19
4.4	Mounting the Top Buret on the bottle	19
4.5	Connecting the drying tube	21
5	Operation	22
5.1	Dispensing settings	22
5.2	Deairing the Top Buret	23
5.3	Titration liquid	24
5.4	Changing the supply bottles during titration	25
5.5	Removing the bottle	26
5.6	Emptying the device	26

6	Calibration and adjustment	27
6.1	Calibrating the Top Buret	27
6.1.1	Measuring the testing volume	27
6.1.2	Calculating the error	27
6.1.3	Evaluating the calibration	28
6.2	Adjusting the Top Buret	28
6.2.1	Adjustment to distilled water	29
6.2.2	Adjustment to a liquid with a different density	29
6.3	Resetting the Top Buret to the factory settings	30
7	Troubleshooting	31
7.1	Troubleshooting	31
8	Maintenance	32
8.1	Cleaning the Top Buret	32
8.1.1	Standard cleaning	33
8.1.2	Intensive cleaning	33
8.2	Disassembling the Top Buret	34
8.3	Replacing the batteries	35
9	Technical data	36
9.1	Ambient conditions	36
9.2	Errors	36
9.3	Parameters for titratable media	36
9.4	Conditions for calibration	36
10	Ordering Information	37
10.1	Devices	37
10.2	Spare parts	37
10.3	Threaded adapter	37
11	Transport, storage and disposal	38
11.1	Transport	38
11.2	Storage	38
11.3	Disposal	39
12	Measurement report	40

1 Operating instructions





1.1 Using this manual

- ▶ Read this operating manual completely before using the device for the first time. Please also note the operating instructions for the accessories, if applicable.
- ▶ This operating manual is part of the product. Thus, it must always be easily accessible.
- ▶ Enclose this operating manual when transferring the device to third parties.

1.2 Danger symbols and danger levels

The safety instructions in this manual appear with the following danger symbols and danger levels:

1.2.1 Danger symbols

	Biohazard		Explosion
	Toxic substances		Hazard point
	Material damage		

1.2.2 Danger levels

DANGER	<i>Will</i> lead to severe injuries or death.
WARNING	<i>May</i> lead to severe injuries or death.
CAUTION	May lead to light to moderate injuries.
NOTICE	May lead to material damage.

1.3 Symbols used

Symbol	Meaning
▶	Handling
1. 2.	Actions in the specified order
•	List
<i>Text</i>	Name of fields in the software
	Useful information

1.4 Abbreviations used

ETFE

Ethylene-tetrafluoroethylene copolymer

FEP

Tetrafluoroethylene-perfluoropropylene copolymer

FKM

Fluororubber

PFA

Perfluoroalkoxy copolymer

PP

Polypropylene

PTFE

Polytetrafluorethylene

PVDF

Polyvinylidene fluoride

2 Product description

2.1 Main illustration

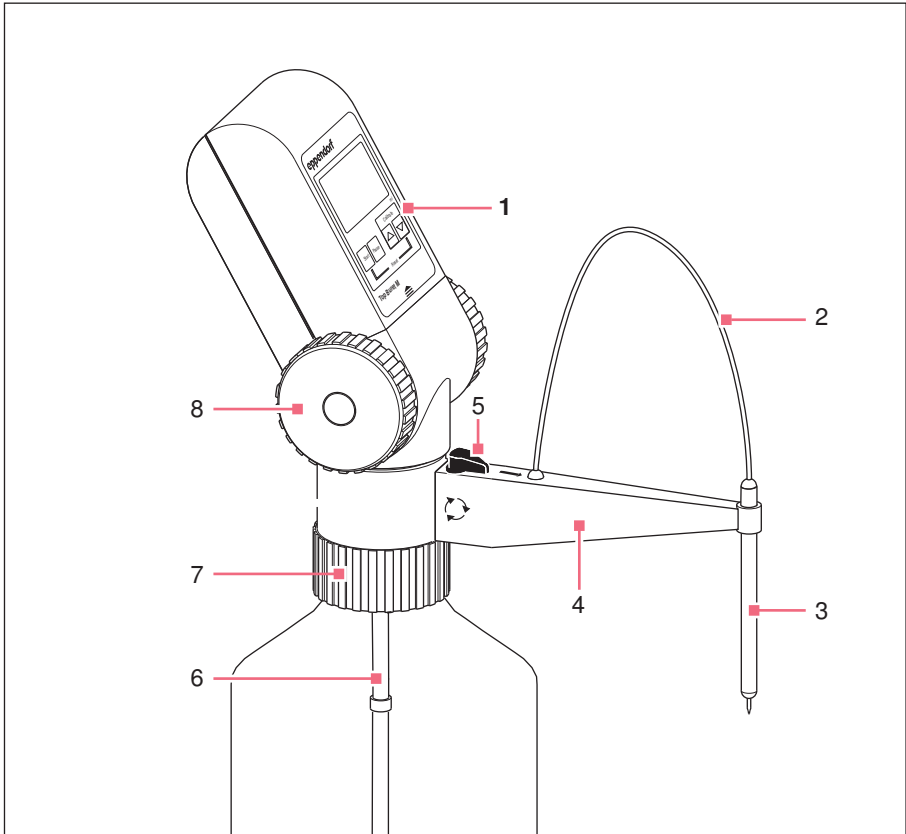

Fig. 2-1: Top Buret M/H

- | | |
|------------------|------------------------------|
| 1 Control panel | 5 Discharge valve toggle |
| 2 Discharge tube | 6 Telescopic aspirating tube |
| 3 Canula holder | 7 Bottle thread |
| 4 Canula arm | 8 Dispensing wheels |

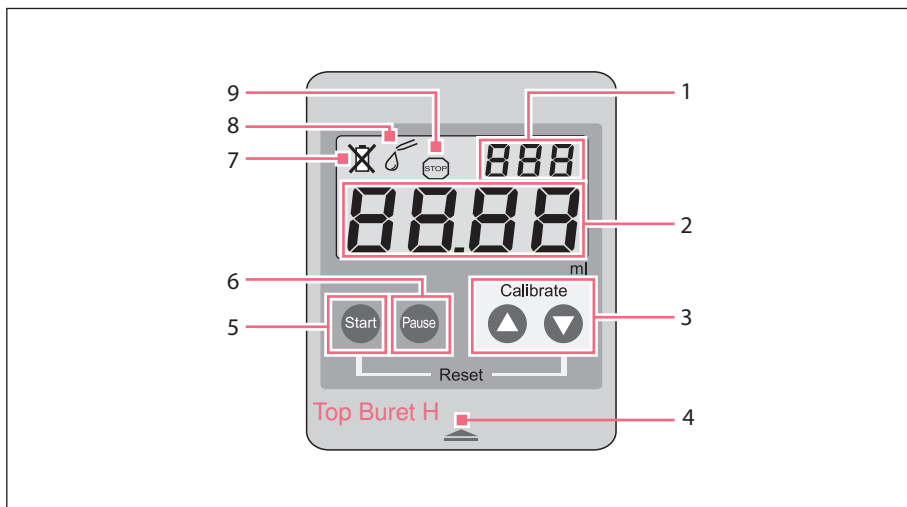

Fig. 2-2: Operating controls

- | | |
|--------------------|-------------------------|
| 1 Calibration mode | 6 Pause key |
| 2 Volume display | 7 Battery flat symbol |
| 3 Arrow keys | 8 Titration mode symbol |
| 4 Opening symbol | 9 Pause symbol |
| 5 Start key | |

2.2 Delivery package

Number	Description
1	Eppendorf Top Buret M 25 mL
or	Eppendorf Top Buret H 50 mL
1	Canula arm
1	Discharge tube with knurled nut
1	Canula holder
1	Telescopic aspirating tube
1	Bottle thread adapter From GL 45 to S 40 (buttress thread), PP From GL 45 to GL 38, PP From GL 38 to GL 32, PP
1	Battery LR03/AAA, 1.5 V, set of 2
1	Eppendorf Top Buret M/H operating manual

2.3 Features

The Top Buret is a bottle-top buret which features a continuous, pulse-free dispensing technique. The Top Buret can dispense volumes between 10 µL and 999.9 mL at a maximum concentration of 1 mol/L.

When the dispensing wheels are fully rotated, the following volumes are dispensed:

- Top Buret M: 2.5 mL
- Top Buret H: 5.0 mL

The Top Buret has two dispensing settings. The dispensing settings are set with the toggle on the canula arm.

- **Titration** →
Titrate liquid from the bottle to a destination vessel.
- **Deairing** ↻
Rinse liquid through the discharge valve into the bottle, e.g., to remove air bubbles.

Product description

Top Buret™
English (EN)

2.4 Materials



NOTICE! Aggressive substances may damage the Top Buret and accessories.

- ▶ Check the chemical resistance before using organic solvents or aggressive chemicals.
- ▶ Follow the cleaning instructions.

The assembly parts of the Top Buret consist of the following materials:

Assembly parts that come into contact with liquid	Assembly parts that do not come into contact with liquid
<ul style="list-style-type: none"> • Borosilicate glass 3.3 (Boro 3.3) • Ethylene-tetrafluoroethylene copolymer (ETFE) • Perfluoroalkoxy copolymer (PFA) • Tetrafluoroethylene-perfluoropropylene copolymer (FEP) • Platinum iridium (Pt-Ir) • Polytetrafluorethylene (PTFE) 	<ul style="list-style-type: none"> • Stainless steel • Fluororubber (FKM) • Polyester • Polypropylene (PP) • Polyvinylidene fluoride (PVDF) • Polyamide (PA) • Polyoxymethylene (POM) • Polyphenylene sulfide (PPS)

3 Safety

3.1 Intended use

The Top Buret is a laboratory device for dispensing aqueous solutions in a volume range between 10 µL and 999.9 mL. Applications in or on the human body (in vivo applications) are not permitted.

The device must not be exposed to an aggressive atmosphere, e.g., HCl vapors. The device must not be autoclaved.

The device is intended for dispensing liquids with the following properties:

- Maximum concentration: 1 mol/L
- Maximum density: 2.2 g/cm³
- Maximum vapor pressure: 50 kPa

The following reagents must not be titrated with the device:

- Liquids which attack PFA, ETFE, PTFE, Boro 3.3 or FEP
- Solutions containing hydrofluoric acid, since they attack borosilicate glass
- Unstable substances because they react catalytically with platinum, e.g., hydrogen peroxide
- Solutions prone to crystallization
- Suspensions containing solid particles
- Fuming acids or highly concentrated alkaline solutions
- Solutions which decompose and form solid particles, e.g., Biuret reagent
- Carbon disulfide, as it is highly flammable

The Top Buret is suitable for dispensing the following titration solutions up to a concentration of 1 mol/L:

- Ammonium iron(II) sulfate solution
- Ammonium thiocyanate solution
- Barium chloride solution
- Bromid bromate solution
- Cerium(IV) sulfate solution
- EDTA solution
- Iron(II) sulfate solution
- Acetic acid

- Iodine solution
- Caustic potash solution
- Potassium bromate solution
- Potassium bromide bromate solution
- Potassium dichromate solution
- Potassium iodate solution
- Potassium permanganate solution
- Potassium thiocyanate solution
- Sodium arsenite solution
- Sodium carbonate solution
- Sodium chloride solution
- Sodium nitrite solution
- Sodium thiosulfate solution
- Caustic soda
- Oxalic acid
- Perchloric acid
- Nitric acid
- Hydrochloric acid
- Sulfuric acid
- Silver nitrate solution
- Tetra-n-butylammonium hydroxide solution
- Zinc sulfate solution

Refer to the information provided by the reagent manufacturers. If you have any questions, contact Eppendorf Service.

3.2 User profile

The device and accessories may only be operated by trained and skilled personnel.

Before using the device, read the operating manual carefully and familiarize yourself with the device's mode of operation.

3.3 Warnings for intended use



DANGER! Risk of explosion.

- ▶ Do not operate the device in areas where work is completed with explosive substances.
 - ▶ Do not use this device to process any explosive or highly reactive substances.
 - ▶ Do not use this device for processing any substances which could generate an explosive atmosphere.
-



WARNING! Damages to health due to infectious liquids and pathogenic germs.

- ▶ When handling infectious liquids and pathogenic germs, observe the national regulations, the biological security level of your laboratory, the material safety data sheets, and the manufacturer's application notes.
- ▶ Wear personal protective equipment.
- ▶ Consult the "Laboratory Biosafety Manual" (Source: World Health Organization, Laboratory Biosafety Manual, as amended) for comprehensive regulations on the handling of risk group II germs or biological materials).



WARNING! Damage to health due to toxic, radioactive or aggressive chemicals.

- ▶ Wear personal protective equipment.
- ▶ Observe the national regulations for handling these substances.
- ▶ Observe the material safety data sheets and manufacturer's application notes.

**CAUTION! Contamination from biological or chemical substances.**

- ▶ Only initiate dispensing if it is safe to do so.
- ▶ Do not place people in danger during dispensing.
- ▶ Turn the dispensing wheels slowly and evenly to prevent spraying.
- ▶ Never point the opening of the discharge tube toward people.

**CAUTION! Poor safety due to incorrect accessories and spare parts.**

The use of accessories and spare parts other than those recommended by Eppendorf may impair the safety, functioning and precision of the device. Eppendorf cannot be held liable or accept any liability for damage resulting from the use of incorrect or non-recommended accessories and spare parts, or from the improper use of such equipment.

- ▶ Only use accessories and original spare parts recommended by Eppendorf.

**NOTICE! Damage to the device due to autoclaving.**

- ▶ Do not autoclave the device.
-

3.4 Information on product liability

In the following cases, the designated protection of the device may be compromised. Liability for any resulting property damage or personal injury is then transferred to the operator:

- The device is not used in accordance with the operating manual.
- The device is used outside of its intended use.
- The device is used with accessories or consumables which are not recommended by Eppendorf.
- The device is maintained or repaired by people not authorized by Eppendorf.
- The user makes unauthorized changes to the device.

4 Installation

4.1 Mounting the device

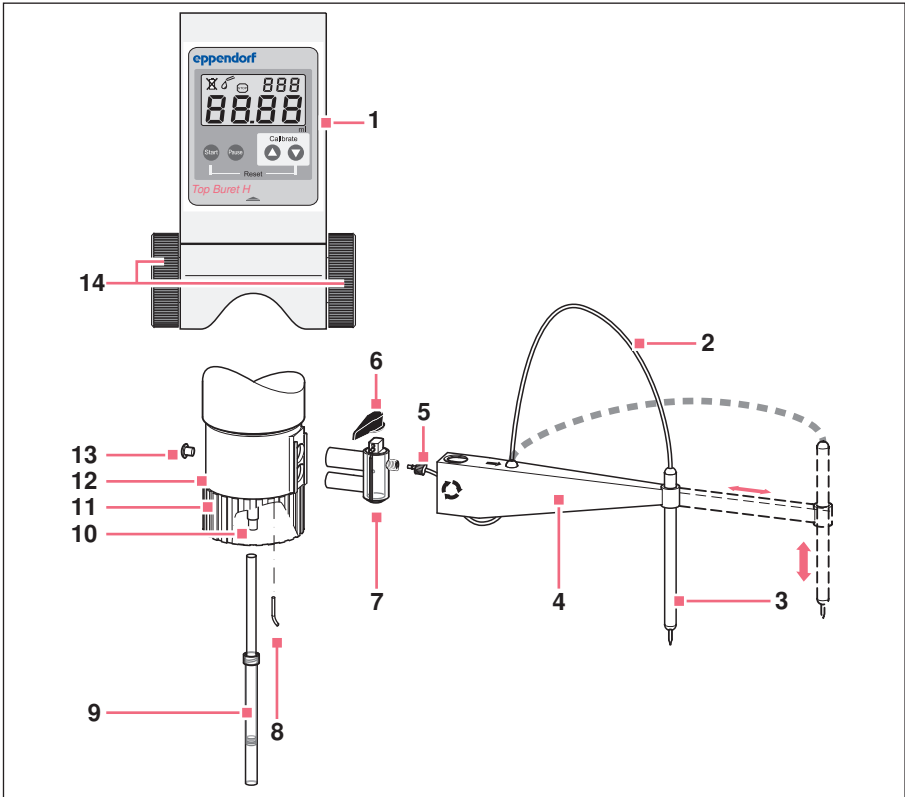
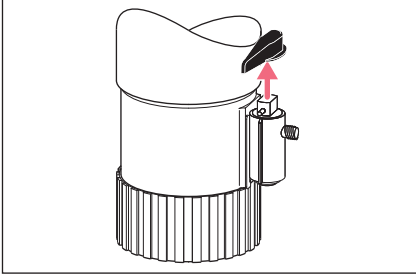

Fig. 4-1: Top Buret

- | | |
|--------------------------|------------------------------|
| 1 Control panel | 8 Recirculation tube |
| 2 Discharge tube | 9 Telescopic aspirating tube |
| 3 Canula holder | 10 connection opening |
| 4 Canula arm | 11 Bottle thread |
| 5 Knurled nut | 12 Valve head |
| 6 Discharge valve toggle | 13 Air vent cover |
| 7 Discharge valve | 14 Dispensing wheels |

To assemble the device, proceed as follows:



1. Rotate the discharge valve toggle to the deairing position. Remove the toggle upwards.

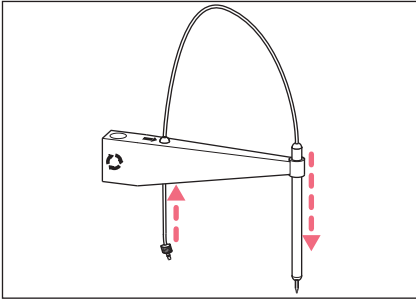

2. The canula holder has gripping nubs on the inside for the canula at one end. Insert the canula holder into the canula arm mount ensuring that the gripping nubs are below.

3. Guide the free end of the discharge tube through the hole in the canula arm from below.

4. Insert the free end of the discharge tube into the canula holder from above until it protrudes slightly at the bottom.

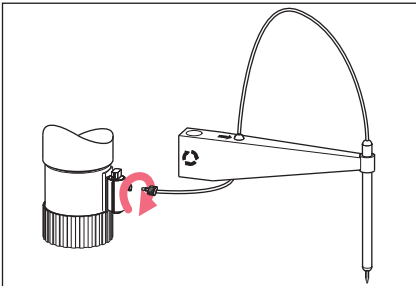

5. Screw the discharge tube with the knurled nut onto the discharge valve.

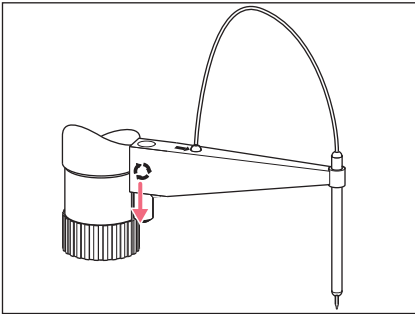

6. Slide the canula arm over the discharge valve from above up to the stop.

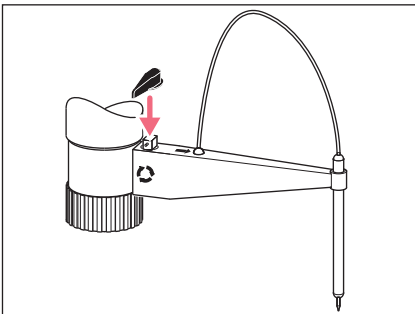

7. Attach the discharge valve toggle.

4.2 Inserting the batteries



NOTICE! Damage to the battery compartment due to inserting the batteries incorrectly.

- ▶ Observe the correct polarity of the batteries.
- ▶ Do not use force.



The display automatically switches on when the batteries are inserted. If the device is not used, the display will switch off after about 5 minutes.

Proceed as follows:

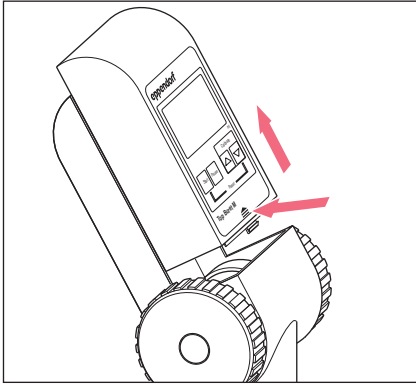

Fig. 4-2: Removing the control panel

1. Press and hold the opening symbol.
2. Slide the control panel upwards and remove it.
3. Remove the battery compartment lid at the back of the control panel.
4. Insert the batteries.
5. Replace the battery compartment lid.
6. Attach the control panel and slide it downwards until it engages.

i To remove the batteries, proceed in the reverse order.

4.3 Mounting the telescopic aspirating tube

The Top Buret conveys the liquid through the telescopic aspirating tube from the supply bottle. Adjust the length of the telescopic aspirating tube to the bottle height to empty the bottle completely.

4.3.1 Extending the telescopic aspirating tube

Prerequisites

- The device has been mounted (see p. 15)
- The bottle is larger than the collapsed telescopic aspirating tube

Proceed as follows:

- ▶ Push the inner tube out of the outer tube until the tube length corresponds to the length of the bottle.

4.3.2 Shortening the telescopic aspirating tube

Prerequisites

- The device has been mounted (see p. 15)
- The bottle is smaller than the collapsed telescopic aspirating tube

Proceed as follows:

1. Push the inner tube completely out of the outer tube.
2. Shorten both tubes to the required length using a pair of scissors.
3. Insert the inner tube into the outer tube.

4.3.3 Mounting the telescopic aspirating tube

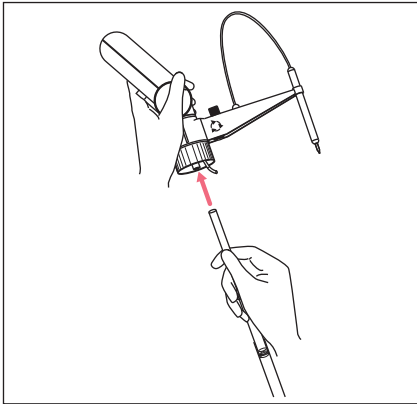

Fig. 4-3: Sliding the telescopic aspirating tube onto the connection opening

1. Slide the inner tube onto the connection opening up to the stop.
2. Pull out the outer tube so that it stops short of the bottom of the bottle.
3. Cut the lower end of the outer tube off at an angle.

4.4 Mounting the Top Buret on the bottle



CAUTION! Personal injury due to incorrect transportation of buret.

If the mounted buret is not transported properly, reagents may be released. Contact with reagents may be harmful to eyes or skin.

- ▶ To transport the mounted buret, grasp the buret with one hand and the bottle with the other hand.
- ▶ Do not hold the buret by the housing.

**CAUTION! Personal injury due to contact with reagents.**

Contact with reagents may be harmful to eyes or skin.

- ▶ Wear personal protective equipment.
- ▶ Make sure that no reagents are leaking from the buret.

The Top Buret can be directly screwed onto bottles with a GL 45 thread. The adapters from the delivery package (see p. 9) and the accessories available for ordering (see p. 37) allow the use on bottles with other threads.

Prerequisites

- The device has been mounted (see p. 15)
- The telescopic aspirating tube has been attached (see p. 18)
- The length of the telescopic aspirating tube has been adjusted to the length of the bottle.

Proceed as follows:

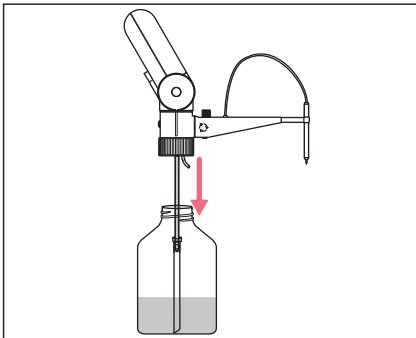

Fig. 4-4: Screwing the Top Buret onto the bottle

1. If the bottle has a different thread to the Top Buret, use the appropriate adapter.
2. Rotate the discharge valve toggle to deairing.
3. Attach the Top Buret onto the bottle from above.
4. If necessary, correct the length of the telescopic aspirating tube.
5. Screw the Top Buret onto the bottle.

4.5 Connecting the drying tube

For the titration of hygroscopic liquids you need a drying tube. The drying tube must be filled with suitable liquid absorbers.

The drying tube is not included in the delivery package. You can order the drying tube as an accessory.

Suitable liquid absorbers:

- Silica gel with a particle size of 1 mm – 3 mm
- CaCO₂
- NaOH pills (5 mm ø, for the absorption of CO₂)

Prerequisites

- The batteries have been inserted (see p. 17)
- The device has been mounted (see p. 15)
- The telescopic aspirating tube has been mounted (see p. 18)
- The device has been screwed onto a bottle (see p. 19)

Proceed as follows:

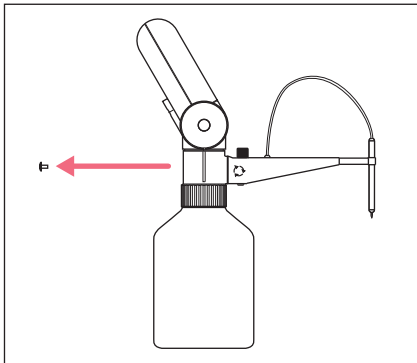

Fig. 4-5: Removing the air vent cover

1. Remove the air vent cover.
2. Insert the drying tube into the opening.
3. Fill the drying tube with moisture absorber.

5 Operation

5.1 Dispensing settings

The Top Buret has two dispensing settings. The dispensing settings are set with the toggle on the canula arm.

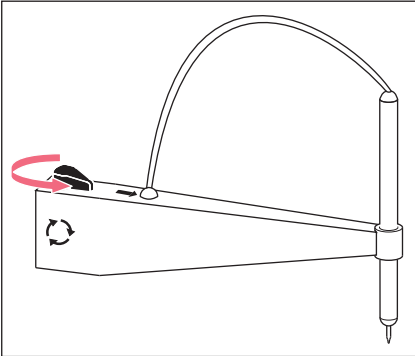

1. Titration

Symbol for the toggle setting: ➔
Titrate liquid from the bottle to a destination vessel.

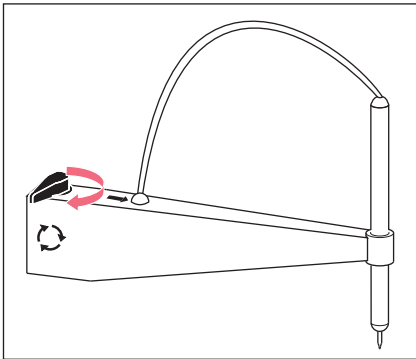

2. Deairing

Symbol for the toggle setting: ↺
Rinse liquid through the discharge valve back into the bottle, e.g., to remove air bubbles.

5.2 Deairing the Top Buret



CAUTION! Personal injury due to contact with reagents.

Contact with reagents may be harmful to eyes or skin.

- ▶ Wear personal protective equipment.
- ▶ Do not point the discharge tube at people.

Air bubbles in the supply lines and in the feeding mechanics will distort the measuring results.

Deair the Top Buret in the following situations:

- Prior to initial operation
- After intensive cleaning
- After changing the bottle
- After a long period of inactivity

Proceed as follows:

Prerequisites

- The device has been completely mounted.

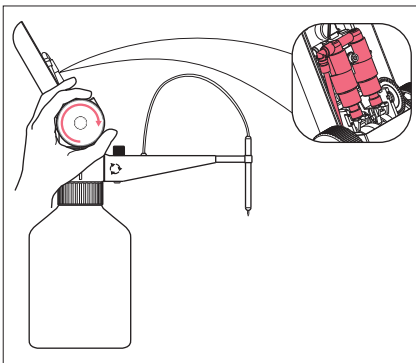

Fig. 5-1: Deairing the interior system

1. Rotate the discharge valve toggle to deairing.
2. Remove the control panel.
3. Rotate the dispensing wheels slowly and evenly forward until there is no more air left in the system.

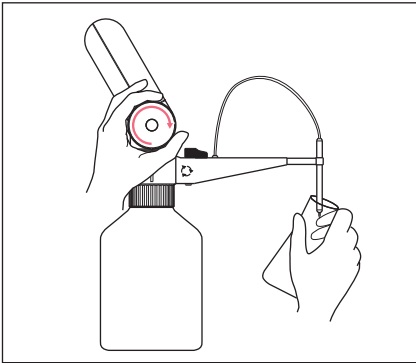

Fig. 5-2: Deairing the discharge tube

4. Rotate the discharge valve toggle to titration.
5. Place a collection vessel below the canula.
6. Rotate the dispensing wheels forward until liquid emerges from the opening of the discharge tube.
7. Attach the control panel.
8. Wipe any chemical residues from the discharge tube.

5.3 Titrating liquid

- i** If you rotate the dispensing wheels backwards, they do not engage. No dispensing of liquid is performed and no volume is counted.
- i** If the Top Buret is not used, the display will switch off after 5 minutes. The titrated volume is stored until the next titration.

Proceed as follows:

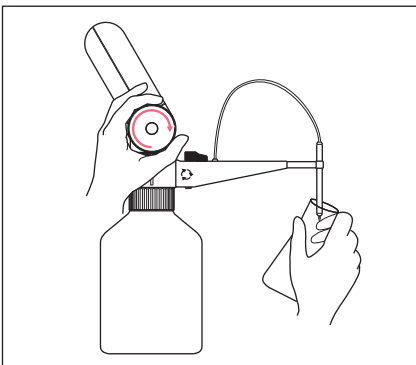

Fig. 5-3: Titration by rotating the dispensing wheel

1. To switch on the display, press the **Start** key.
 The display shows either *0.00* or the volume of the last titration.
2. Press the **Start** key to set the volume display to *0.00*.
3. Pull out the canula arm to the desired length.
4. Hold a collection vessel below the discharge tube.
5. Rotate the discharge valve toggle to titration.

6. Press the **Start** key to set the volume display to *0.00*.
7. Pull out the canula arm to the desired length.
8. Hold a collection vessel below the discharge tube.
9. Rotate the discharge valve toggle to titration.
10. Rotate the dispensing wheels forward to dispense liquid.
11. To end titration, rotate the discharge valve toggle to deairing.
12. To avoid the dispensing of liquid from the discharge tube, set the valve toggle to recirculation.

5.4 Changing the supply bottles during titration

You can change the supply bottles during a titration sequence without changing the displayed volume.

Proceed as follows:

1. Press the **Pause** key.
 On the display, the **Stop** symbol appears. The titrated value is stored.
2. Remove the bottle (see p. 26).
3. Mount the new bottle (see p. 19).
4. Deair the device (see p. 23).
5. Press the **Pause** key again.
 The display is enabled. The display shows the stored value and the titration symbol .
6. Continue titration.

5.5 Removing the bottle

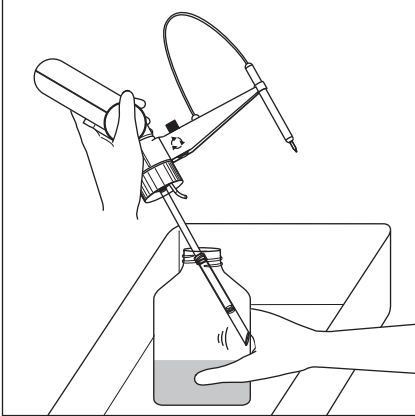

Fig. 5-4: Emptying the telescopic aspirating tube

1. Rotate the discharge valve toggle to deairing.
2. Place the Top Buret with bottle into a suitable collecting vessel.
3. Unscrew the device from the bottle in a counterclockwise direction.
4. Lift the Top Buret until the telescopic aspirating tube is no longer immersed in the liquid.
5. Gently tap the telescopic aspirating tube against the inside of the bottle. The residual liquid from the telescopic aspirating tube runs into the bottle.

5.6 Emptying the device

Before changing the liquid and before cleaning, the Top Buret must be emptied.

Proceed as follows:

Prerequisites

- The bottle has been unscrewed (see p. 26)

1. Mount the Top Buret onto an empty bottle.
2. Place a collection vessel below the canula.
3. Rotate the discharge valve toggle to titration.
4. Rotate the dispensing wheels forward until no more liquid runs out of the discharge tube.
5. Rotate the discharge valve toggle to deairing.
6. Rotate the dispensing wheels forward until no more liquid runs out of the recirculation tube.

i To remove the reagents completely, clean the device.

6 Calibration and adjustment

6.1 Calibrating the Top Buret

The Top Buret has been calibrated with distilled or deionized water. You can carry out a gravimetric test of the Top Buret error. The procedure is described in detail in DIN EN ISO 8655.6.

You need the following auxiliary equipment:

- Distilled water
- Calibrated analytical balance
- Beaker

6.1.1 Measuring the testing volume

Prerequisites

- The device and auxiliary equipment must have the same temperature (20 °C – 25 °C, ±0.5 °C).

Proceed as follows:

1. Set up the calibrated analytical balance at a vibration and draft-free location.
2. Place a beaker on the balance.
3. With the Top Buret M, titrate 25 mL of distilled water into the beaker and record the weight.
4. Repeat step 3 10 times.
5. With the Top Buret H, titrate 50 mL of distilled water into the beaker and record the weight.
6. Repeat step 5 10 times.

6.1.2 Calculating the error

1. Calculate the volume of the water.

Density of water (ρ) at 16 °C – 21 °C = 0.998 g/mL

Density of water (ρ) at 22 °C – 25 °C = 0.997 g/mL

$$V = \frac{m}{\rho}$$

2. Calculate the average value of the volumes.

$$\bar{V} = 1/n \sum_{i=1}^n V_i$$

3. Calculate the inaccuracy (e_s) using the nominal volume (V_s).

$$e_s = \frac{\bar{V} - V_s}{V_s} \times 100 \%$$

- \bar{V} = actual volume (average value of the weighings)
- V_s = nominal volume (Top Buret M = 25 mL, Top Buret H = 50 mL)

4. Calculate the standard deviation (s_r).

$$s_r = \sqrt{\frac{\sum_{i=1}^n (V_i - \bar{V})^2}{n-1}}$$

- s_r = standard deviation
- n = number of dispensing steps
- V_i = measured value (weight of the sample)
- \bar{V} = actual volume (average value of the weighings)

5. Calculate the imprecision (CV).

$$CV = \frac{100 \times s_r}{\bar{V}}$$

6.1.3 Evaluating the calibration

1. Compare the results for inaccuracy and imprecision with table (see p. 36).
2. If the errors are within the tolerance range specified in the table, no adjustment is necessary.
3. If the errors are outside the tolerance range, adjust the device or contact a service technician.

6.2 Adjusting the Top Buret

The Top Buret has been calibrated and adjusted before delivery. Adjust the Top Buret in the following situations:

- The calibration error with distilled water is outside the tolerance range
- The density of the titrated liquid differs from the density of distilled water

Calibration is only possible with a testing volume between 10 mL – 90 mL.

If the testing volume is < 10 mL, the display shows:



If the testing volume is > 90 mL, the display shows:



- i To display the set adjustment value, either press the ▲ or ▼ arrow key in titration mode. After you release the key, the display automatically returns to the last volume display.

6.2.1 Adjustment to distilled water

Proceed as follows:

1. Carry out the measurement of the testing volumes and calculate the average value of the volumes (see *Calibrating the Top Buret* on p. 27).
2. Use the average value of the volumes that you have obtained from the calibration.
3. Press the **Pause** key.
The volume is saved.
4. Press and hold the ▲ and ▼ arrow keys at the same time for 3 seconds.
The display shows *CAL* at the top right
5. Set the calculated average value of the volumes using the ▲ and ▼ arrow keys.
6. Press the **Start** key.
 - The set value is accepted
 - The display is reset to zero
 - The adjustment is ended
 - The display shows *C* at the top right. The display indicates that the factory settings have been changed.

6.2.2 Adjustment to a liquid with a different density

1. Set up the calibrated analytical balance at a vibration and draft-free location.
2. Place a beaker on the balance.

3. With the Top Buret M, titrate 25 mL of the test liquid into the beaker and record the weight.
4. Repeat step 3 10 times.
5. With the Top Buret H, titrate 50 mL of the test liquid into the beaker and record the weight.
6. Repeat step 5 10 times.
7. Calculate the volume of the standard solution.

$$V = \frac{m}{\rho}$$

8. Calculate the average value of the volumes.

$$\bar{V} = 1/n \sum_{i=1}^n V_i$$

9. Press the **Pause** key.
The volume is saved.
10. Press and hold the ▲ and ▼ arrow keys at the same time for 3 seconds.
The display shows *CAL* at the top right
11. Set the calculated average value of the volumes using the ▲ and ▼ arrow keys.
12. Press the **Start** key.
 - The set value is accepted
 - The display is reset to zero
 - The adjustment is ended
 - The display shows *C* at the top right. The display indicates that the factory settings have been changed.

6.3 Resetting the Top Buret to the factory settings

The reset function is used to restore the factory settings. If you have adjusted the device, the display will show a *C*. When you restore the factory settings again, the *C* will disappear.

1. Press the **Start** key to switch on the Top Buret.
2. Press and hold the **Start** and ▼ keys at the same time for 3 seconds to activate the reset function.
 - The display *C* disappears.
 - The factory settings have been restored.

7 Troubleshooting

7.1 Troubleshooting

Symptom/message	Cause	Remedy
<ul style="list-style-type: none"> Air is aspirated. The titrated liquid contains air bubbles. 	<ul style="list-style-type: none"> The device was not sufficiently deaired. 	<ul style="list-style-type: none"> ▶ Deair the device (see p. 23).
	<ul style="list-style-type: none"> The telescopic aspirating tube has not been mounted completely. 	<ul style="list-style-type: none"> ▶ Slide the telescopic aspirating tube firmly onto the connection opening (see p. 18).
	<ul style="list-style-type: none"> The telescopic aspirating tube is damaged. 	<ul style="list-style-type: none"> ▶ Shorten the telescopic aspirating tube or replace it.(see p. 18).
	<ul style="list-style-type: none"> The telescopic aspirating tube does not immerse into the liquid. 	<ul style="list-style-type: none"> ▶ Lengthen the telescopic aspirating tube until it is immersed in the liquid (see p. 18).
	<ul style="list-style-type: none"> The connection opening is damaged. 	<ul style="list-style-type: none"> ▶ Send in the device for repair.
Liquid is not aspirated.	<ul style="list-style-type: none"> The connection opening is clogged. 	<ul style="list-style-type: none"> ▶ Clean the device (see p. 32).
The titration volume is too small.	<ul style="list-style-type: none"> The telescopic aspirating tube has not been mounted completely. 	<ul style="list-style-type: none"> ▶ Slide the telescopic aspirating tube firmly onto the connection opening (see p. 18).
	<ul style="list-style-type: none"> The telescopic aspirating tube is damaged. 	<ul style="list-style-type: none"> ▶ Shorten the telescopic aspirating tube or replace it (see p. 18).
	<ul style="list-style-type: none"> The device is incorrectly adjusted. 	<ul style="list-style-type: none"> ▶ Set the device to the factory adjustment (see p. 30).
	<ul style="list-style-type: none"> The connection opening is damaged. 	<ul style="list-style-type: none"> ▶ Send in the device for repair.
The display shows the  symbol.	<ul style="list-style-type: none"> The batteries are flat. 	<ul style="list-style-type: none"> ▶ Replace the batteries.

8 Maintenance

8.1 Cleaning the Top Buret



CAUTION! Personal injury due to contact with reagents during cleaning.

The feeding mechanics, valves, telescopic aspirating tube and discharge tube are filled with reagents. Reagents enter the bottle with the cleaning solution.

- ▶ Wear personal protective equipment.
 - ▶ Discard the cleaning solution after cleaning.
-



The feeding mechanics consists of tubing and the valves inside the housing. These parts may become heavily contaminated. These parts may only be cleaned by authorized personnel. If the feeding mechanics need to be cleaned, contact Eppendorf Service.



Replace the discharge tube when it is heavily contaminated or damaged.



To disinfect the Top Buret, clean the buret with a suitable disinfectant, e.g., 70% ethanol.

Clean the Top Buret in the following situations:

- Prior to changing the reagent
- Prior to storage
- Prior to maintenance and repair work
- Daily after use with solutions prone to crystallization or highly concentrated alkaline solutions
- The dispensing wheels are hard to turn
- The device is heavily contaminated.

8.1.1 Standard cleaning

Prerequisites

- The Top Buret has been emptied (see p. 26).

Proceed as follows:

1. Mount the Top Buret onto a bottle filled with a neutral cleaning solution.
2. Place a collection vessel below the discharge tube.
3. Switch the toggle to titration.
4. Rotate the dispensing wheels at least 10 times slowly and evenly forward.
5. Switch the toggle to deairing.
6. Rotate the dispensing wheels at least 10 times slowly and evenly forward.
7. Remove the device from the bottle.
8. To evacuate the Top Buret, rotate the dispensing wheels.
9. Screw the Top Buret onto a bottle filled with distilled water.
10. Repeat steps 2 to 6.
11. Remove the Top Buret from the bottle.
12. Rotate the dispensing wheels until the Top Buret is completely emptied.

8.1.2 Intensive cleaning

We recommend performing intensive cleaning in the following situations:

- The device is heavily contaminated.
- The dispensing wheels are hard to turn.
- After titration of highly crystalline liquid.

Prerequisites

- The device has been cleaned according to the standard procedure (see p. 33).
- The device has been disassembled (see p. 34).

Proceed as follows:

1. Clean the telescopic aspirating tube with a soft bottle brush.
2. Clean all parts with a soft brush and a mild cleaning agent.
3. Wipe the housing without the control panel with a damp cloth and a mild cleaning agent.
4. Rinse all parts with distilled water.

5. Allow all assembly parts to dry.
6. Reassemble the Top Buret.
Carry out assembly in the reverse order to disassembly (see p. 34).
7. Using distilled water, check that the device is not leaking and that the device is functioning correctly.
8. Calibrate the Top Buret. (see p. 27).

8.2 Disassembling the Top Buret

- i** When disassembling the canula arm, be careful not to bend the discharge tube.

Prerequisites

- The Top Buret has been cleaned according to the standard procedure (see p. 33).

Proceed as follows:

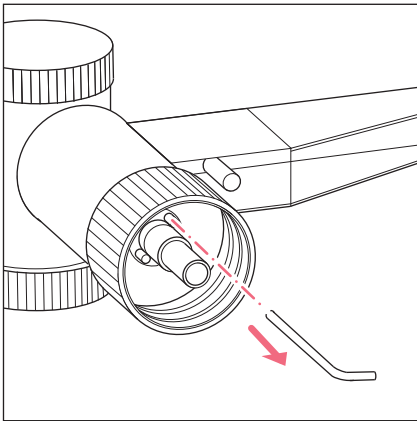



Fig. 8-1: Removing the recirculation tube from the valve head

1. Unscrew the Top Buret from the bottle in a counterclockwise direction.
2. Remove the telescopic aspirating tube from the connection opening.
3. Remove the recirculation tube from the front hole in the valve head.
4. Rotate the discharge valve toggle to deairing and remove it upwards.
5. Remove the canula arm from the grooves of the discharge valve from above.
6. Unscrew the discharge tube knurled nut from the discharge valve thread.
7. Remove the discharge tube from the discharge valve.
8. Remove the discharge tube from the canula holder and canula arm.
9. Remove the canula holder from the canula arm.
10. Pull the discharge valve out of the valve head.

8.3 Replacing the batteries

If the batteries are flat, the display will show the symbol .

- ▶ Replace the batteries (see p. 17).
- ▶ Dispose of the old batteries in an environmentally friendly manner (Tab. on p. 39).

9 Technical data

9.1 Ambient conditions

Ambience	Only for use in indoors.
Ambient temperature	15 °C – 40°C
Relative humidity	0 % – 90 %, non-condensing.
Atmospheric pressure	Use up to a height of 2000 m above sea level.

9.2 Errors

Model	Testing volume	Inaccuracy	Imprecision
Top Buret M	25 mL	±0.2%	≤ 0.1 %
Top Buret H	50 mL	±0.2%	≤ 0.1 %

9.3 Parameters for titratable media

Medium temperature	15 °C – 40°C
Maximum density	2.2 g/cm ³
Maximum vapor pressure	50 kPa

9.4 Conditions for calibration

Test conditions and test evaluation in accordance with ISO 8655, part 6. Test with analytical balance with evaporation protection, approved by the board of weights and measures.

The errors were determined under the following conditions:

Liquid	Water according to ISO 3696
Number of determinations	10
Ambient temperature	20 °C – 25°C ± 0.5 °C
Dispensing liquid	Dispensing on the tube inner wall

10 Ordering Information

10.1 Devices

Order no. (International)	Description
4965 000.017	Eppendorf Top Buret M 25 mL
4965 000.025	Eppendorf Top Buret H 50 mL

10.2 Spare parts

Order no. (International)	Description
4965 612.004	Discharge tube with knurled nut
4965 611.008	Cannula holder
4965 616.000	Discharge valve with toggle
4960 805.009	Telescopic aspirating tube
4960 851.000	Drying tube without drying agent
4965 620.007	Air vent cover/filter connection
4965 625.009	Battery LR03/AAA, 1.5 V, 2 pieces

10.3 Threaded adapter

Order no. (International)	Description
	Bottle thread adapter
4960 800.040	From GL 32 to GL 25, PP
4960 800.139	From GL 32 to GL 27, PP
4960 800.058	From GL 32 to GL 28, PP
4960 800.163	From GL 38 to GL 32, PP
4960 800.155	From GL 45 to GL 38, PP
4960 800.147	From GL 45 to S 40 (Buttress thread), PP
4960 800.082	From GL 32 to NS 19/26, PP
4960 800.090	From GL 32 to NS 24/29, PP
4960 800.104	From GL 32 to NS 29/32, PP
	Thread adapter
4960 832.006	for 5 L-jerrycan from 45 mm to 17/8" thread

11 Transport, storage and disposal

11.1 Transport

Decontamination before shipment

If you are shipping the device to the authorized Technical Service for repairs or to your authorized dealer for disposal please note the following:



WARNING! Risk to health from contaminated device

- ▶ Observe the notes on the decontamination certificate. You find it as a PDF file on our website (www.eppendorf.com/decontamination).
- ▶ Decontaminate all the parts you would like to dispatch.
- ▶ Include the fully completed decontamination certificate in the package.



NOTICE! Damage as a result of incorrect packing.

Eppendorf AG is not liable for damage caused by improper packing.

- ▶ The device may only be stored and transported in its original packaging.

Tab. 11-1: Transport conditions

	Air temperature	Relative humidity	Atmospheric pressure
General transport	15 °C – 40°C	0 % – 90 %, non-condensing.	Up to a height of 2000 m above sea level.
Air freight	-20°C – 50°C	0 % – 90 %, non-condensing.	Up to a height of 12200 m above sea level.

11.2 Storage

	Air temperature	Relative humidity	Atmospheric pressure
Storage	15 °C – 40°C	0 % – 90 %, non-condensing.	Up to a height of 2000 m above sea level.

11.3 Disposal

In case the product is to be disposed of, the relevant legal regulations are to be observed.

Information on the disposal of electrical and electronic devices in the European Community:

Within the European Community, the disposal of electrical devices is regulated by national regulations based on EU Directive 2002/96/EC pertaining to waste electrical and electronic equipment (WEEE).

According to these regulations, any devices supplied after August 13, 2005, in the business-to-business sphere, to which this product is assigned, may no longer be disposed of in municipal or domestic waste. They are marked with the following symbol to indicate this:

As disposal regulations may differ from country to country within the EU, please contact your supplier if necessary.



WARNING! Risk of explosion and fire due to overheated accumulators and batteries.

- ▶ Do not heat accumulators and batteries to over 80 °C and do not throw them into fires.

Disposing of accumulators and batteries

Do not dispose of accumulators and batteries as household waste. Dispose of accumulators and batteries according to the locally applicable legal regulations.



12 Measurement report



EG-Konformitätserklärung EC Conformity Declaration

Das bezeichnete Produkt entspricht den einschlägigen grundlegenden Anforderungen der aufgeführten EG-Richtlinien und Normen. Bei einer nicht mit uns abgestimmten Änderung des Produktes oder einer nicht bestimmungsgemäßen Anwendung verliert diese Erklärung ihre Gültigkeit.

The product named below fulfills the relevant fundamental requirements of the EC directives and standards listed. In the case of unauthorized modifications to the product or an unintended use this declaration becomes invalid.

Produktbezeichnung, Product name:

Top Buret M/H 4965 / Bottletop Buret 25/50

Produkttyp, Product type:

manuelle Bürette / bottletop buret

Einschlägige EG-Richtlinien/Normen, Relevant EC directives/standards:

2004/108/EG, EN 61326-1

2011/65/EU

H.-G. Köh

Vorstand, Board of Management:

19.10.2012

Hamburg, Date:

Reinhold

Projektmanagement, Project Management:



eppendorf

Eppendorf AG · Barkhausenweg 1 · 22339 Hamburg · Germany

Evaluate your manual

Give us your feedback.
www.eppendorf.com/manualfeedback

Your local distributor: www.eppendorf.com/worldwide
Eppendorf AG · Hamburg · Germany · Phone: +49 40 538 01-0